

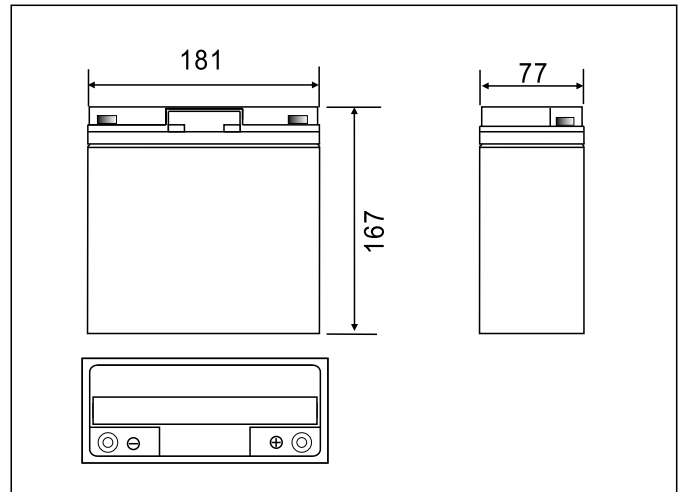

● Applications

- Electric tools
- Electric toys
- Emergency lighting
- Electronic instruments
- Medical equipment
- Alarm and security systems
- Solar power systems
- Wind power systems
- Telecommunication equipments
- Uninterruptible power supplies

● Outer Dimensions (mm)



Nominal Voltage		12V
Rated Capacity (20 hour rate)		18Ah
Dimensions	Total Height	167±2mm(6.57 inches)
	Height	167±2mm(6.57 inches)
	Length	181±2mm(7.13 inches)
	Width	77±2mm(3.03 inches)
Weight Approx		5.25kg(11.58 lbs)± 4%

● Characteristics

Capacity 25°C(77°F)	20 hour rate(0.90A)	18.0 AH
	10 hour rate(1.70A)	17.0 AH
	5 hour rate(3.12A)	15.6AH
	1 hour rate(11.7 A)	11.7AH
Internal Resistance	Full charged Battery at 25°C(77°F)	16m Ω
Capacity affected by Temperature (20hour rate)	40°C(104°F)	102%
	25°C(77°F)	100%
	0°C(32°F)	85%
	-15°C(5°F)	65%
Self-Discharge at 25°C(77°F)	Capacity after 3 month storage	91%
	Capacity after 6 month storage	82%
	Capacity after 12 month storage	64%
Charge (constant voltage)	Cycle	Initial Charging Current Less than 5.4 A Voltage 14.50-14.90V
	Float	Voltage 13.50-13.80V

● Terminal Type (mm)

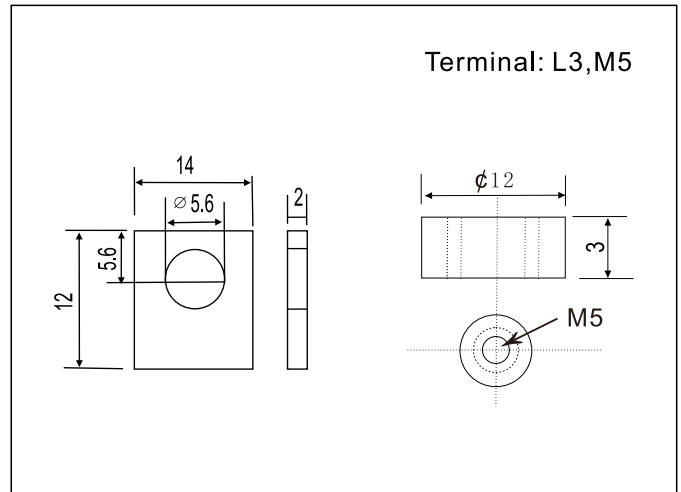

Constant Current(AMP) and Constant Power(Watt) Characteristics at 25°C(77°F)

F.V/TIME	10min	15min	30min	1h	2h	3h	4h	5h	8h	10h	20h
9.60V	A	44.1	34.5	19.3	11.8	6.39	4.59	3.67	3.12	2.02	0.91
	w	497	394	221	137	74.8	54.5	43.7	37.3	24.2	11.0
9.90V	A	42.7	33.7	18.9	11.6	6.36	4.56	3.65	3.10	2.01	0.91
	w	482	384	216	135	74.4	54.2	43.5	37.0	24.1	10.9
10.2V	A	41.0	32.5	18.3	11.3	6.30	4.53	3.63	3.08	1.99	0.91
	w	462	370	210	131	73.7	53.8	43.2	36.8	23.9	10.9
10.5V	A	39.2	31.4	17.9	11.1	6.21	4.50	3.60	3.06	1.98	0.90
	w	442	358	205	129	72.6	53.5	36.5	36.5	23.8	10.8
10.8V	A	37.0	29.7	17.2	10.8	6.05	4.37	3.49	2.97	1.92	0.88
	w	418	339	197	125	70.8	51.9	35.4	35.4	23.0	10.6

● Discharge Characteristics(25°C)

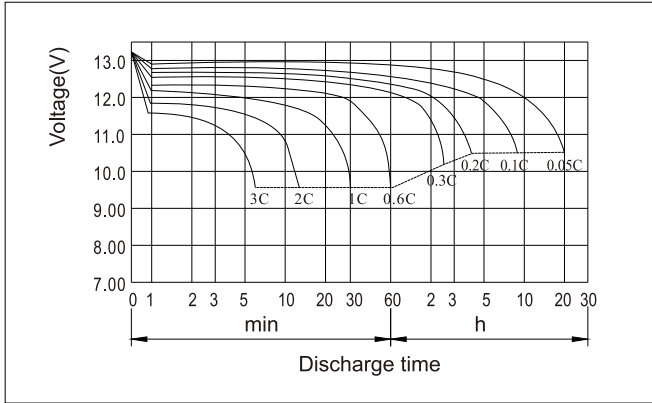

● Charging Characteristics(25°C)

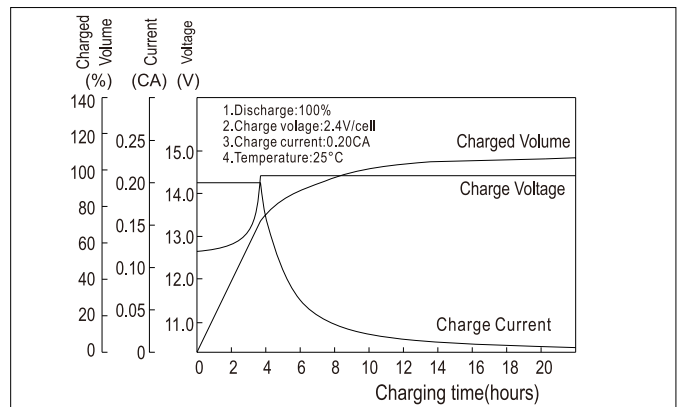

● Effect of Temperature on Capacity

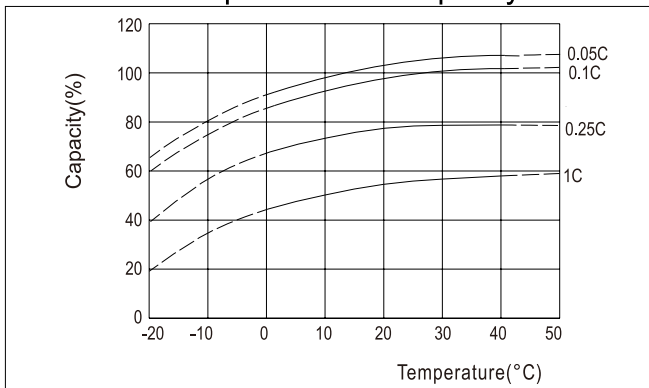

● Self-discharge Characteristics

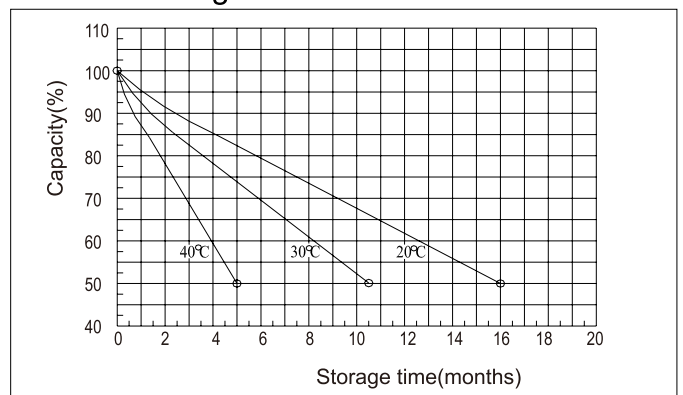

● The Relationship for Open Circuit Voltage and Residual Capacity (25°C)

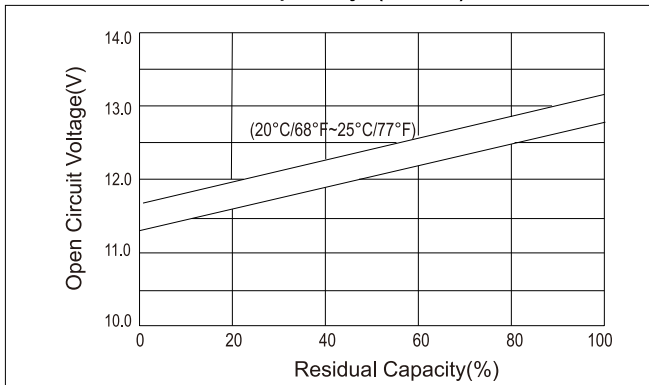

● The Relationship for Charging Voltage and Temperature

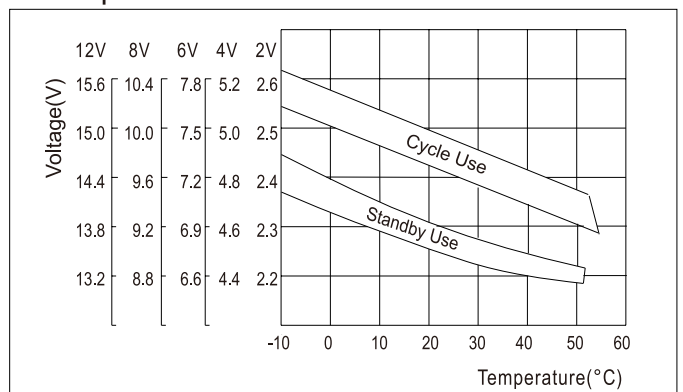

● Floating Life on Temperature

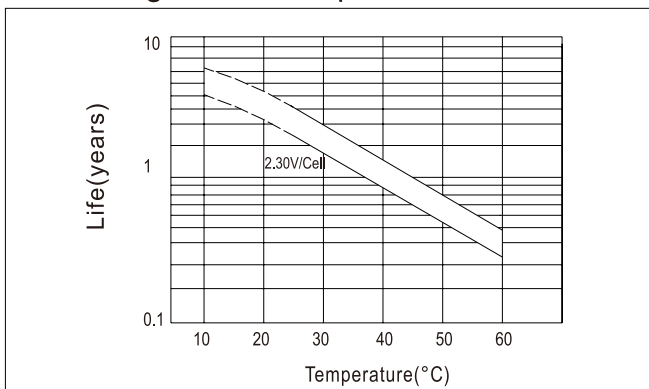

● Cycle Life on D.O.D (25°C)

