



Specifications

Nominal Voltage		12V
Rated Capacity (10 hour rate)		70Ah
Dimensions	Total Height	214±2mm(8.43 inches)
	Height	208±2mm(8.19 inches)
	Length	259±2mm(10.2 inches)
	Width	169±2mm(6.65 inches)
Weight Approx		21.5kg(47.41 lbs)±4%

Characteristics

Capacity 25°C(77°F)	10 hour rate(7.0A) 5 hour rate(12.5A) 1hour rate(43.4A)	70 AH 62.5 AH 43.4AH
Internal Resistance	Full charged Battery at 25°C(77°F)	6.5mΩ
Capacity affected by Temperature (10hour rate)	40°C(104°F) 25°C(77°F) 0°C(32°F) -15°C(5°F)	102% 100% 85% 65%
Self-Discharge at 25°C(77°F)	Capacity after 3 month storage Capacity after 6 month storage Capacity after 12 month storage	91% 82% 64%
Charge (constant voltage)	Cycle	Initial Charging Current Less than 17.5 A Voltage 14.50-14.90V
	Float	Voltage 13.50-13.80V

Applications

- Electric tools
- Electric toys
- Emergency lighting
- Electronic instruments
- Medical equipment
- Alarm and security systems
- Solar power systems
- Wind power systems
- Telecommunication equipments
- Uninterruptible power supplies

Outer Dimensions (mm)

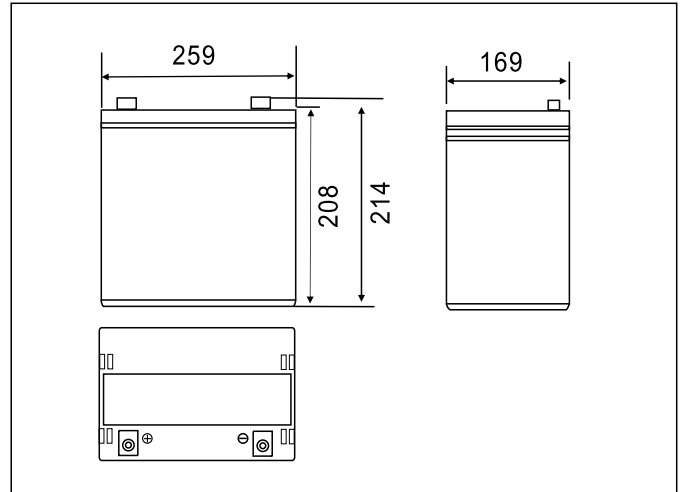

Terminal Type (mm)

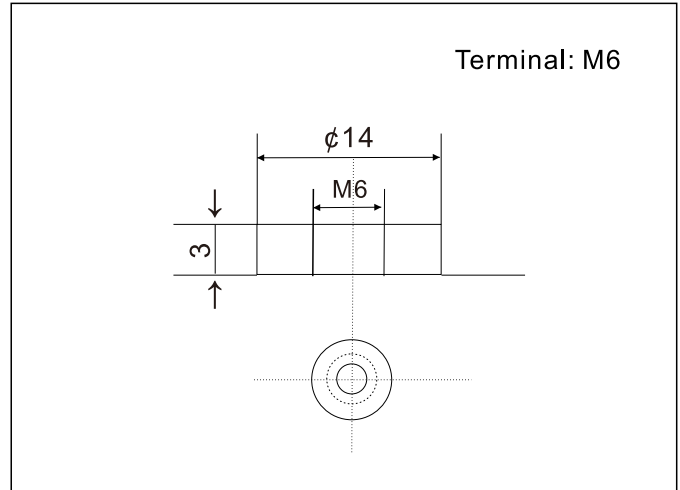

Constant Current(AMP) and Constant Power(Watt) Characteristics at 25°C(77°F)

F.V/TIME		10min	15min	30min	1h	2h	3h	4h	5h	8h	10h	20h
9.60V	A	150	117	70.7	43.8	25.6	17.9	14.6	12.5	8.57	7.13	3.74
	w	1619	1281	793	500	297	210	172	148	102	85.1	44.9
9.90V	A	145	114	69.3	43.2	25.5	17.7	14.6	12.4	4.52	7.11	3.73
	w	1571	1250	777	492	295	209	171	147	101	84.9	44.8
10.20V	A	139	110	67.2	42.1	25.3	17.6	14.5	12.3	8.46	7.09	3.72
	w	1506	1204	754	480	293	207	170	146	100	84.7	44.7
10.50V	A	133	106	65.5	41.2	24.9	17.5	14.4	12.3	8.40	7.05	3.70
	w	1441	1163	735	470	288	206	169	145	99.8	84.2	44.4
10.80V	A	126	100	63.2	40.1	24.3	17.0	13.9	11.9	8.15	7.00	3.68
	w	1360	1102	709	457	281	200	164	140	96.8	83.6	44.1

● Discharge Characteristics(25°C)

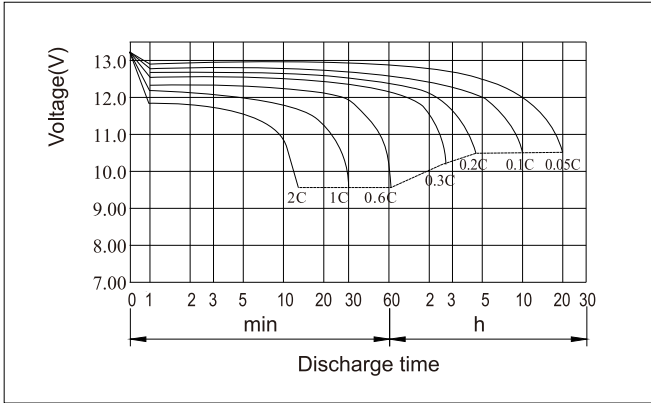

● Charging Characteristics(25°C)

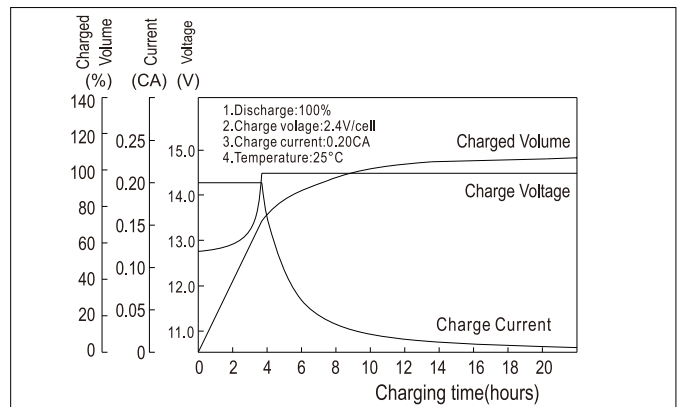

● Effect of Temperature on Capacity

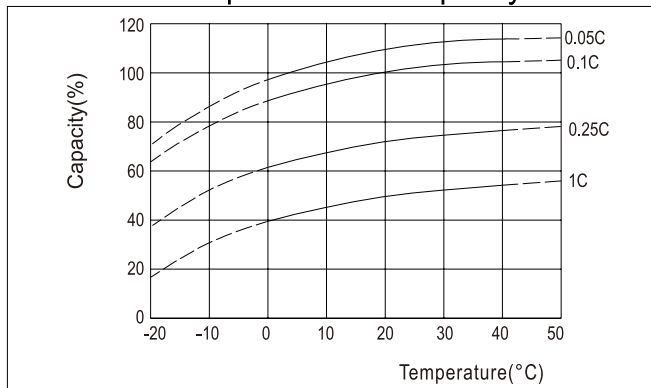

● Self-discharge Characteristics

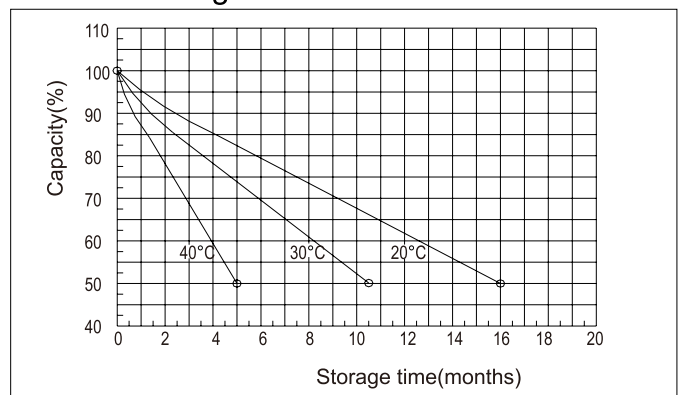

● The Relationship for Open Circuit Voltage and Residual Capacity (25°C)

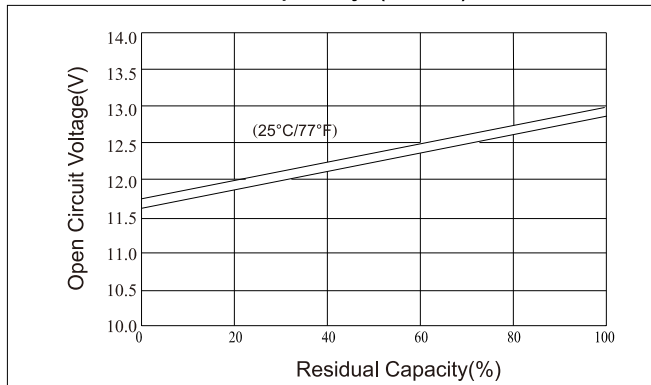

● The Relationship for Charging Voltage and Temperature

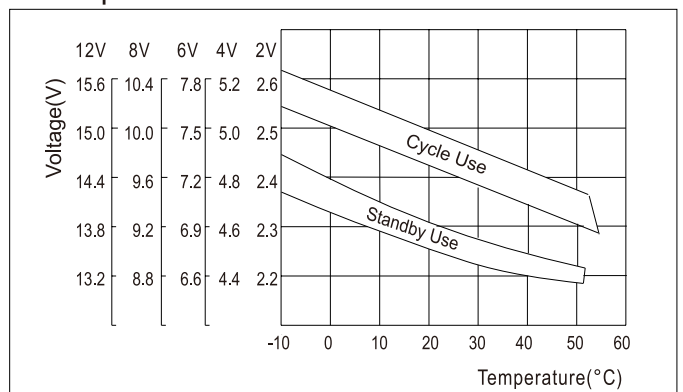

● Floating Life on Temperature

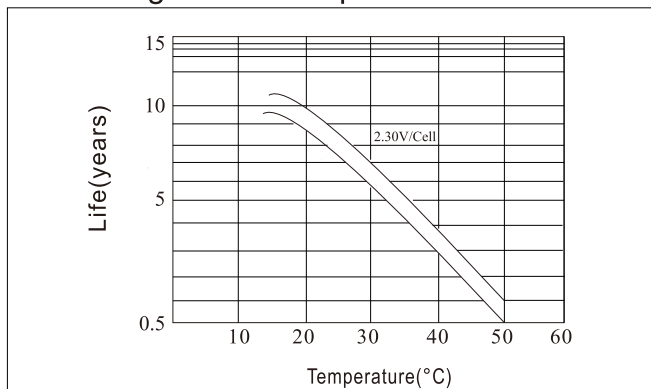

● Cycle Life on D.O.D (25°C)

