



### ● Specifications

Nominal Voltage		6V
Rated Capacity (20 hour rate)		7.2Ah
Dimensions	Total Height	100±2mm(3.94 inches)
	Height	94±2mm(3.70 inches)
	Length	151±2mm(5.94 inches)
	Width	34±2mm(1.93 inches)
Weight Approx		1.18kg(2.59 lbs)± 4%

### ● Characteristics

Capacity 25°C(77°F)	20 hour rate(0.36A)	7.20 AH
	10 hour rate(0.68A)	6.80 AH
	5 hour rate(1.25A)	6.25AH
	1hour rate(4.48A)	4.68 AH
Internal Resistance	Full charged Battery at 25°C(77°F)	16m Ω
Capacity affected by Temperature (20hour rate)	40°C(104°F)	102%
	25°C(77°F)	100%
	0°C(32°F)	85%
	-15°C(5°F)	65%
Self-Discharge at 25°C(77°F)	Capacity after 3 month storage	91%
	Capacity after 6 month storage	82%
	Capacity after 12 month storage	64%
Charge (constant voltage)	Cycle	Initial Charging Current Less than 2.16A Voltage 7.20-7.50V
	Float	Voltage 6.75-6.90V

### ● Applications

- Electric tools
- Electric toys
- Emergency lighting
- Electronic instruments
- Medical equipment
- Alarm and security systems
- Solar power systems
- Wind power systems
- Telecommunication equipments
- Uninterruptible power supplies

### ● Outer Dimensions (mm)

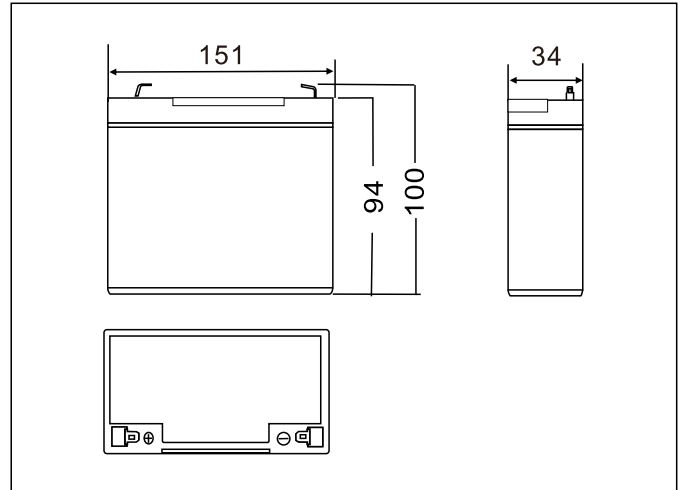

### ● Terminal Type (mm)

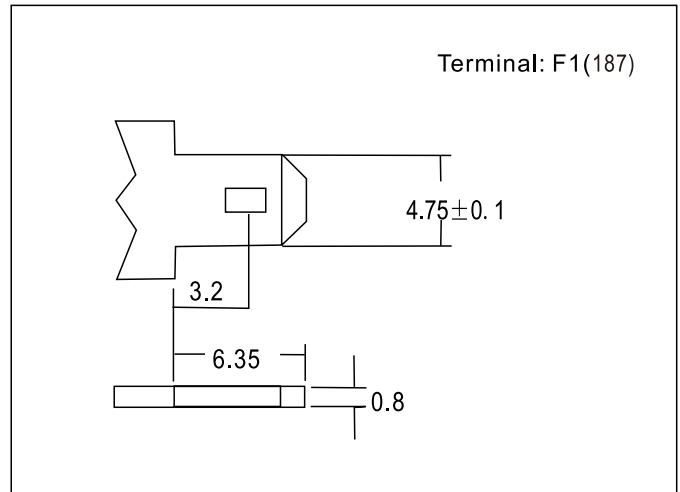

### Constant Current(AMP) and Constant Power(Watt) Characteristics at 25°C(77°F)

F.V/TIME	5min	10min	15min	30min	1h	2h	3h	4h	5h	10h	20h	
4.80V	A	27.4	17.3	13.7	7.63	4.68	2.56	1.84	1.47	1.25	0.68	0.37
	w	153	97.5	78.0	43.7	27.1	15.0	10.9	8.75	7.45	4.08	2.19
4.95V	A	26.5	16.8	13.4	7.48	4.61	2.54	1.83	1.46	1.24	0.68	0.36
	w	148	94.5	76.1	42.9	26.7	14.9	10.8	8.70	7.41	4.06	2.18
5.10V	A	25.4	16.1	12.9	7.25	4.49	2.52	1.81	1.45	1.23	0.67	0.36
	w	142	90.6	73.3	41.5	26.0	14.7	10.8	8.64	7.36	4.04	2.17
5.25V	A	24.4	15.4	12.4	7.07	4.40	2.48	1.80	1.44	1.22	0.67	0.36
	w	136	86.7	70.8	40.5	25.5	14.5	10.7	8.58	7.31	4.02	2.16
5.40V	A	23.0	14.5	11.8	6.82	4.27	2.42	1.75	1.40	1.19	0.66	0.35
	w	128	81.9	67.1	39.1	24.7	14.2	10.4	8.32	7.09	3.94	2.12

### ● Discharge Characteristics(25°C)

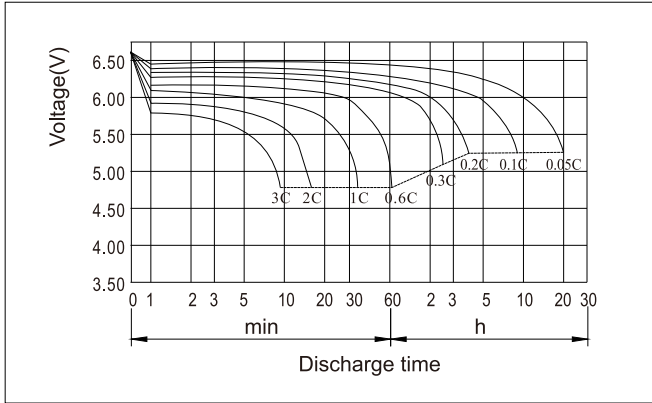

### ● Charging Characteristics(25°C)

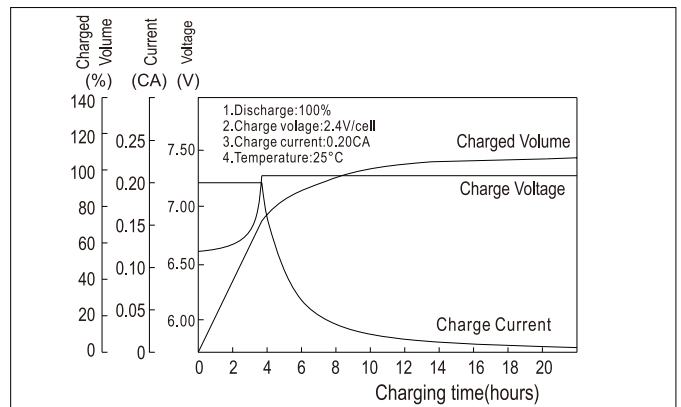

### ● Effect of Temperature on Capacity

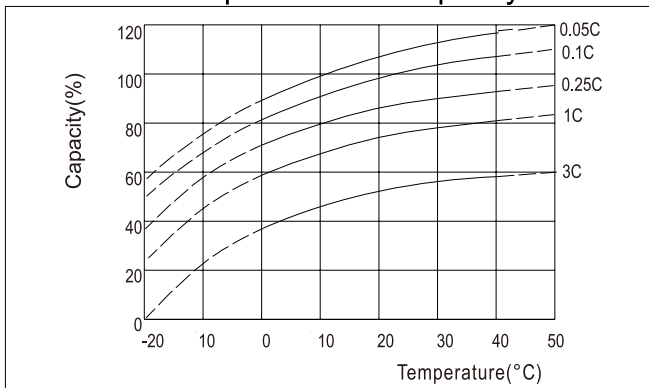

### ● Self-discharge Characteristics

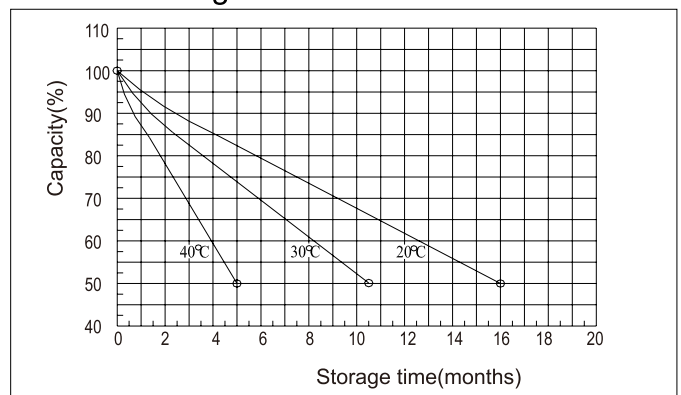

### ● The Relationship for Open Circuit Voltage and Residual Capacity (25°C)

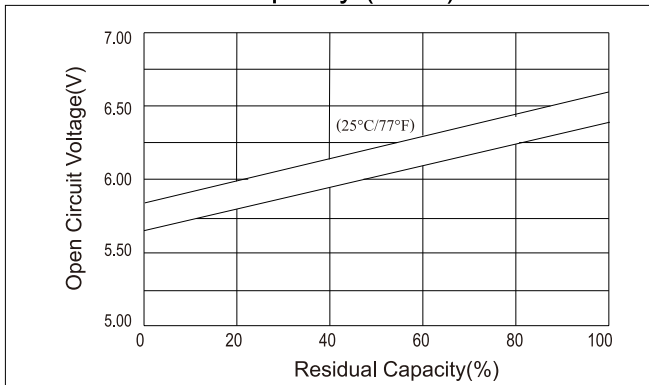

### ● The Relationship for Charging Voltage and Temperature

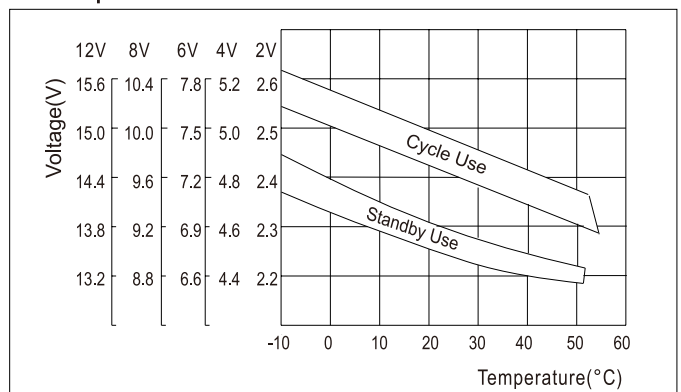

### ● Floating Life on Temperature

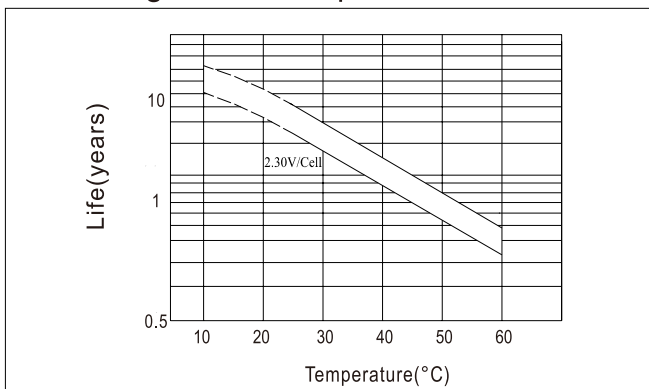

### ● Cycle Life on D.O.D (25°C)

