



● Specifications

Nominal Voltage		12V
Rated Capacity (20 hour rate)		17Ah
Dimensions	Total Height	167±2mm(6.57 inches)
	Height	167±2mm(6.57 inches)
	Length	181±2mm(7.13 inches)
	Width	77±2mm(3.03 inches)
Weight Approx		5.05kg(11.14 lbs)± 4%

● Characteristics

Capacity 25°C(77°F)	20 hour rate(0.85A)	17.0 AH
	10 hour rate(1.60A)	16.0 AH
	5 hour rate(2.94A)	14.7AH
	1 hour rate(11.1 A)	11.1AH
Internal Resistance	Full charged Battery at 25°C(77°F)	17mΩ
Capacity affected by Temperature (20hour rate)	40°C(104°F)	102%
	25°C(77°F)	100%
	0°C(32°F)	85%
	-15°C(5°F)	65%
Self-Discharge at 25°C(77°F)	Capacity after 3 month storage	91%
	Capacity after 6 month storage	82%
	Capacity after 12 month storage	64%
Charge (constant voltage)	Cycle	Initial Charging Current Less than 5.1 A Voltage 14.50-14.90V
	Float	Voltage 13.50-13.80V

● Applications

- Electric tools
- Electric toys
- Emergency lighting
- Electronic instruments
- Medical equipment
- Alarm and security systems
- Solar power systems
- Wind power systems
- Telecommunication equipments
- Uninterruptible power supplies

● Outer Dimensions (mm)

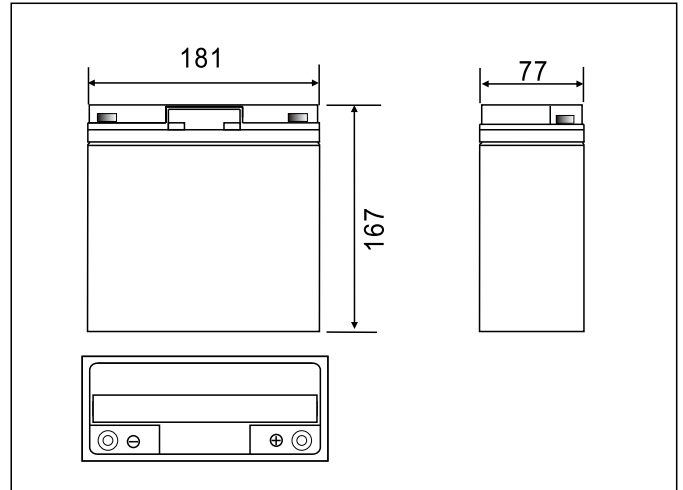

● Terminal Type (mm)

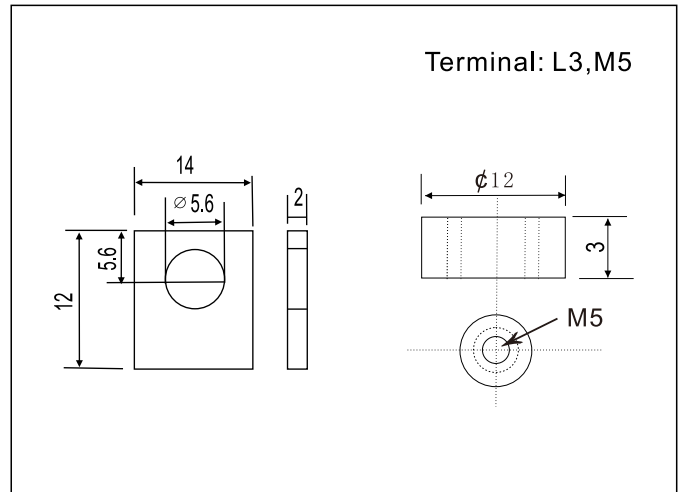

Constant Current(AMP) and Constant Power(Watt) Characteristics at 25°C(77°F)

F.V/TIME	10min	15min	30min	1h	2h	3h	4h	5h	8h	10h	20h
9.60V	A	40.8	32.3	18.0	11.1	6.04	4.34	3.47	2.95	1.91	0.86
	w	460	368	207	128	70.7	51.5	41.3	35.2	22.9	10.4
9.90V	A	39.6	31.5	17.7	10.9	6.01	4.31	3.45	2.93	1.90	0.86
	w	446	359	202	126	70.2	51.2	41.1	35.0	22.8	10.3
10.2V	A	37.9	30.4	17.1	10.6	5.95	4.28	3.42	2.91	1.88	0.86
	w	428	346	196	123	69.6	50.8	40.8	34.7	22.6	10.3
10.5V	A	36.3	29.3	16.7	10.4	5.86	4.25	3.40	2.89	1.87	0.85
	w	410	334	191	120	68.6	50.5	40.5	34.5	22.4	10.2
10.8V	A	34.3	27.8	16.1	10.1	5.71	4.12	3.30	2.80	1.81	0.83
	w	387	317	184	117	66.8	49.0	39.3	33.5	21.8	10.0

● Discharge Characteristics(25°C)

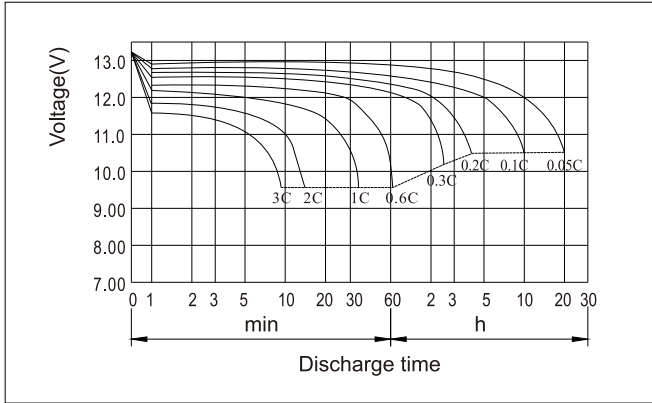

● Charging Characteristics(25°C)

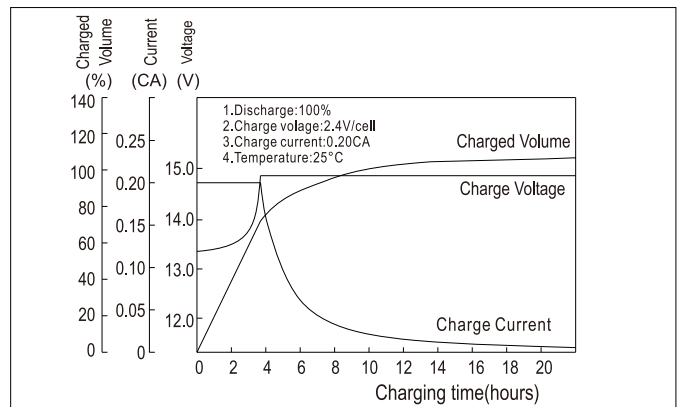

● Effect of Temperature on Capacity

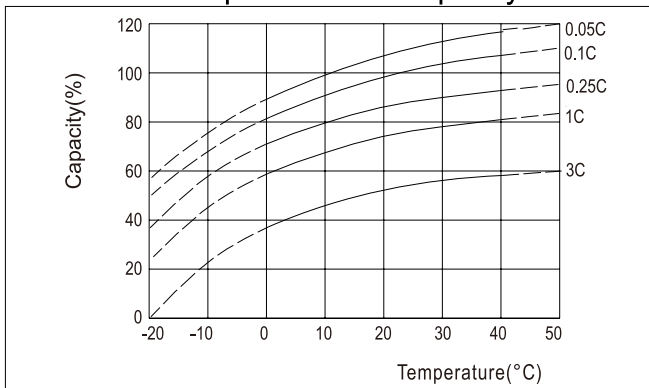

● Self-discharge Characteristics

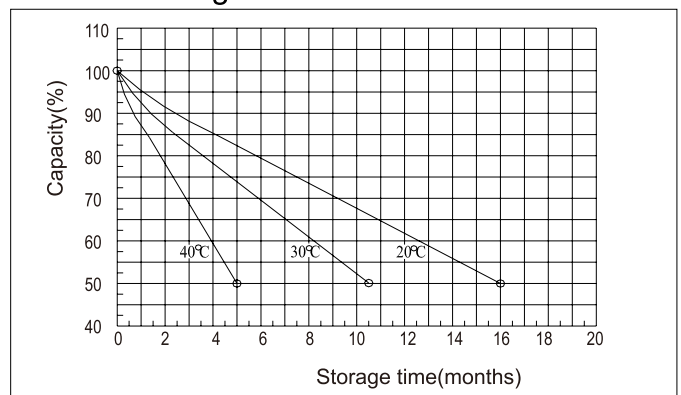

● The Relationship for Open Circuit Voltage and Residual Capacity (25°C)

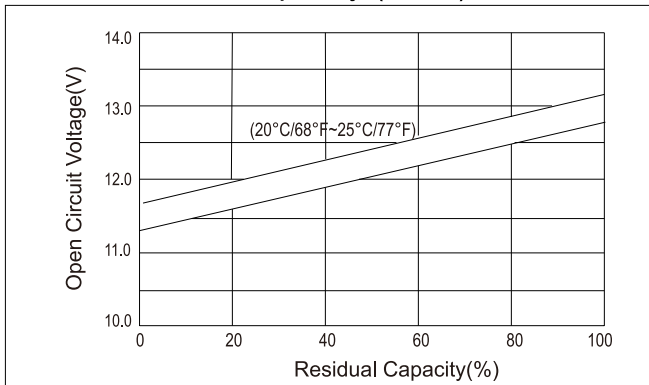

● The Relationship for Charging Voltage and Temperature

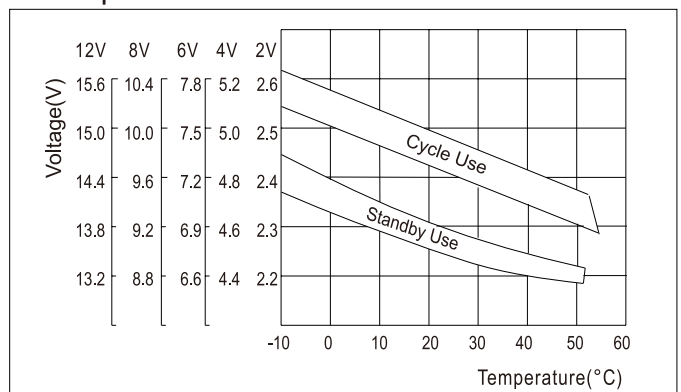

● Floating Life on Temperature

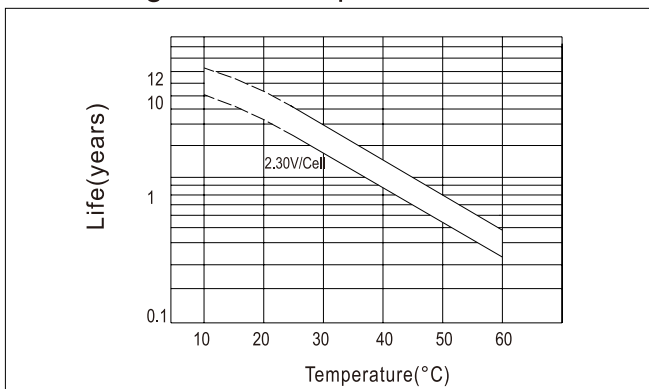

● Cycle Life on D.O.D (25°C)

