



● Applications

- Electric tools
- Electric toys
- Emergency lighting
- Electronic instruments
- Medical equipment
- Alarm and security systems
- Solar power systems
- Wind power systems
- Telecommunication equipments
- Uninterruptible power supplies

● Specifications

Nominal Voltage		12V
Rated Capacity (10 hour rate)		50Ah
Dimensions	Total Height	215±2mm(8.45 inches)
	Height	211±2mm(8.30 inches)
	Length	230±2mm(9.10 inches)
	Width	138±2mm(5.43 inches)
Weight Approx		14kg(30.80 lbs)±4%

● Outer Dimensions (mm)

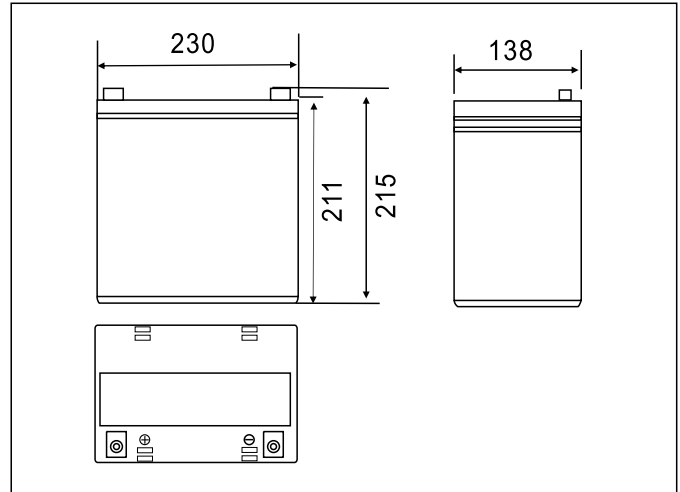

● Characteristics

Capacity 25°C(77°F)	10 hour rate(5.0A) 5 hour rate(8.8A) 1 hour rate(33A)	50 AH 44 AH 31AH
Internal Resistance	Full charged Battery at 25°C(77°F)	7.5m Ω
Capacity affected by Temperature (10hour rate)	40°C(104°F) 25°C(77°F) 0°C(32°F) -15°C(5°F)	102% 100% 85% 65%
Self-Discharge at 25°C(77°F)	Capacity after 3 month storage Capacity after 6 month storage Capacity after 12 month storage	91% 82% 64%
Charge (constant voltage)	Cycle	Initial Charging Current Less than 12.5A Voltage 14.50-14.90V
	Float	Voltage 13.50-13.80V

● Terminal Type (mm)

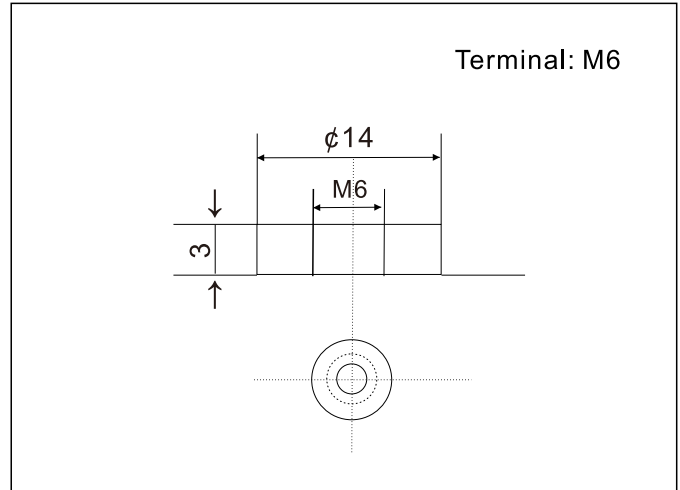

Constant Current(AMP) and Constant Power(Watt) Discharge Table at 25°C(77°F)

Time		10min	15min	30min	1h	2h	3h	4h	5h	8h	10h	20h
9.60V	A	105	82.5	50	31	18.3	12.8	10.5	8.93	6.12	5.09	2.67
	w	1134	906	561	353	212	150	123	105	72.7	60.8	32.1
9.90V	A	102	80.5	49	30.5	18.2	12.7	10.4	8.87	6.08	5.08	2.67
	w	1100	884	550	348	210	149	122	105	72.3	60.7	32.0
10.20V	A	97.7	77.6	47.5	29.8	18	12.6	10.3	8.81	6.04	5.07	2.66
	w	1055	851	533	339	208	148	121	104	71.8	60.5	31.9
10.50V	A	93.5	74.9	46.4	29.2	17.7	12.5	10.3	8.75	6.00	5.04	2.64
	w	1009	823	520	333	147	147	121	103	71.3	60.1	31.7
10.80V	A	88.2	71.0	44.7	28.3	17.3	12.1	9.94	8.49	5.82	5.00	2.63
	w	953	779	501	322	143	143	117	100	69.1	59.7	31.5

● Discharge Characteristics(25°C)

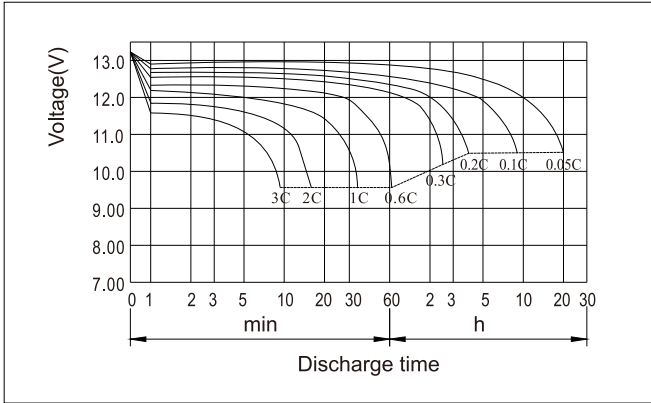

● Charging Characteristics(25°C)

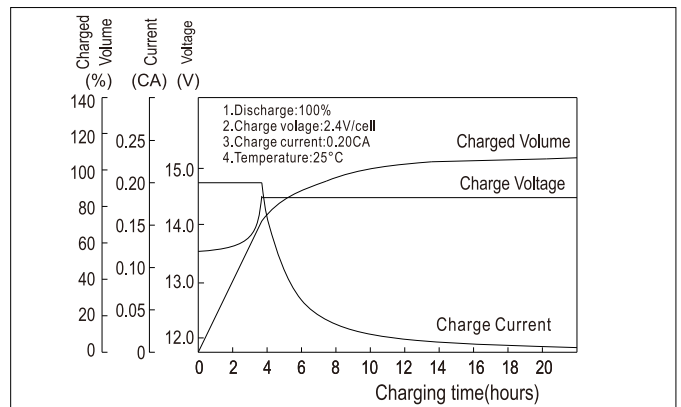

● Effect of Temperature on Capacity

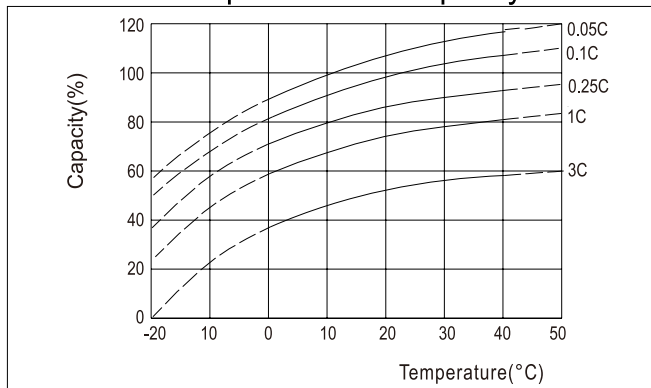

● Self-discharge Characteristics

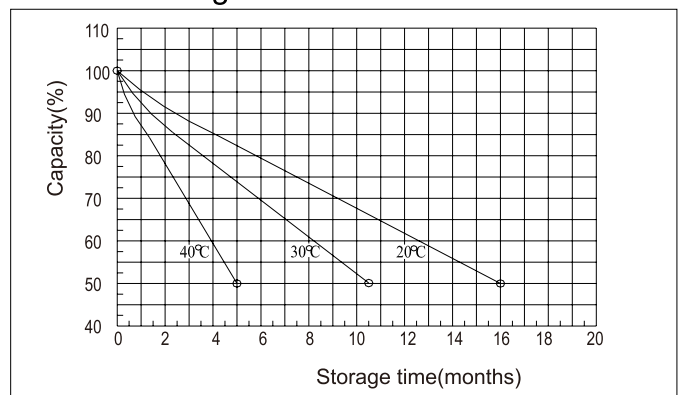

● The Relationship for Open Circuit Voltage and Residual Capacity (25°C)

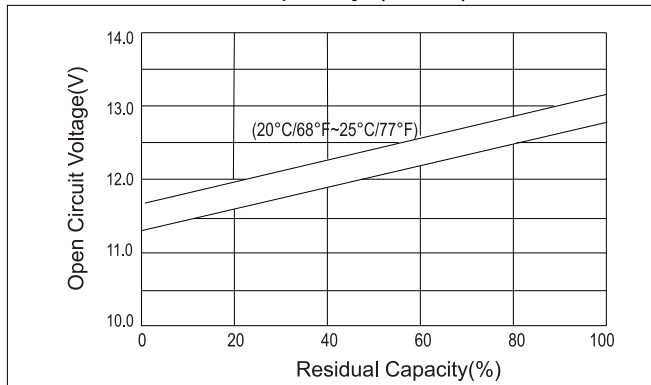

● The Relationship for Charging Voltage and Temperature

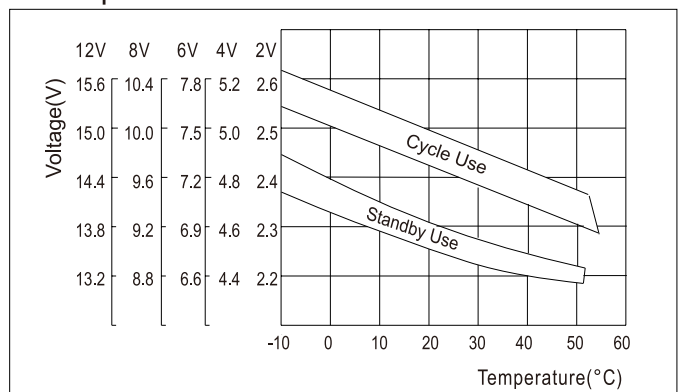

● Floating Life on Temperature

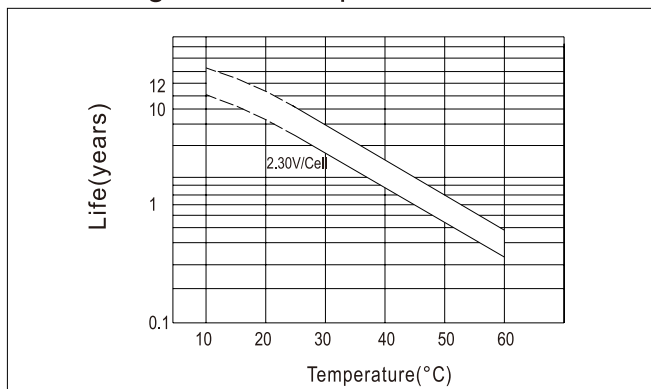

● Cycle Life on D.O.D (25°C)

