



### ● Applications

- Electric tools
- Electric toys
- Emergency lighting
- Electronic instruments
- Medical equipment
- Alarm and security systems
- Solar power systems
- Wind power systems
- Telecommunication equipments
- Uninterruptible power supplies

### ● Specifications

Nominal Voltage		12V
Rated Capacity (10 hour rate)		250Ah
Dimensions	Total Height	223±2mm(8.77 inches)
	Height	220±2mm(8.71 inches)
	Length	520±2mm(20.47 inches)
	Width	267±2mm (10.51 inches)
Weight Approx		67kg(147.74 lbs)±4%

### ● Outer Dimensions (mm)

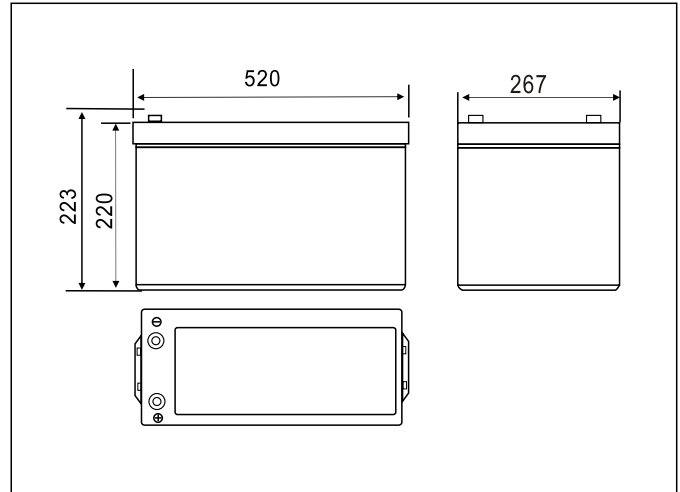

### ● Characteristics

Capacity 25°C(77°F)	10 hour rate(25A) 5 hour rate(44.6A) 1hour rate(155A)	250 AH 223 AH 155AH
Internal Resistance	Full charged Battery at 25°C(77°F)	2.6m Ω
Capacity affected by Temperature (10hour rate)	40°C(104°F) 25°C(77°F) 0°C(32°F) -15°C(5°F)	102% 100% 85% 65%
Self-Discharge at 25°C(77°F)	Capacity after 3 month storage Capacity after 6 month storage Capacity after 12 month storage	91% 82% 64%
Charge (constant voltage)	Cycle	Initial Charging Current Less than 62.5A Voltage 14.50-14.90V
	Float	Voltage 13.50-13.80V

### ● Terminal Type (mm)

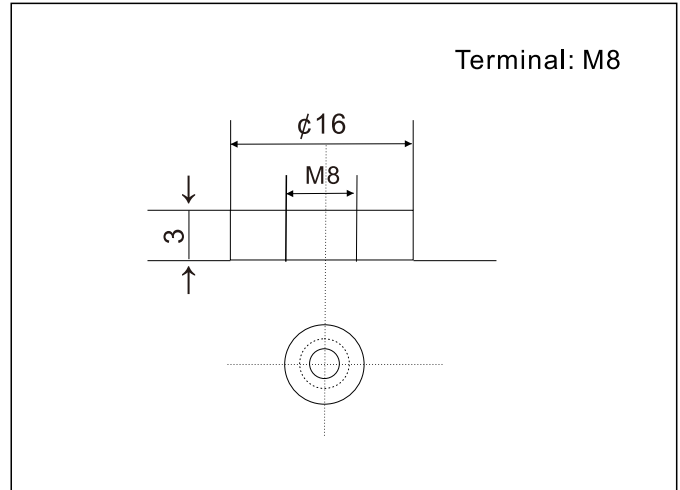

### Constant Current(AMP) and Constant Power(Watt) Discharge Table at 25°C(77°F)

Time	15min	30min	1h	2h	3h	4h	5h	6h	8h	10h	20h	
9.60V	A	413	250	155	91.4	63.8	52.3	44.6	39.0	30.6	25.5	13.4
	w	4529	2805	1767	1058	750	615	527	461	364	304	160
9.90V	A	403	245	153	90.8	63.	52.0	44.4	38.8	30.4	25.4	13.3
	w	4421	2749	1740	1052	745	611	514	458	361	303	160
10.20V	A	388	238	149	90.0	62.9	51.6	44.1	38.5	30.2	25.3	13.3
	w	4257	2665	1696	1042	740	607	521	455	359	302	160
10.50V	A	375	232	146	88.7	62.5	51.3	43.8	38.3	30.0	25.2	13.2
	w	4113	2600	1663	1027	735	603	517	452	356	301	159
10.80V	A	355	223	141	86.4	60.6	49.7	42.4	37.1	29.1	25.0	13.1
	w	3895	2505	1612	1001	713	585	502	439	346	299	158

### ● Discharge Characteristics(25°C)

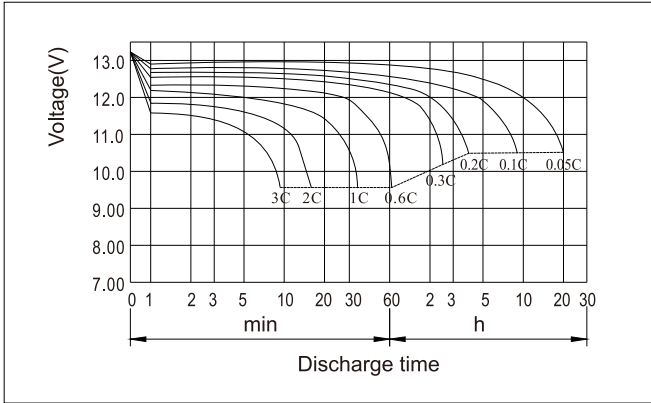

### ● Charging Characteristics(25°C)

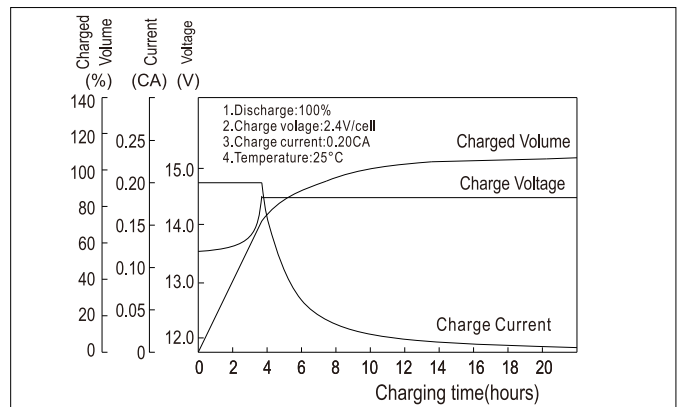

### ● Effect of Temperature on Capacity

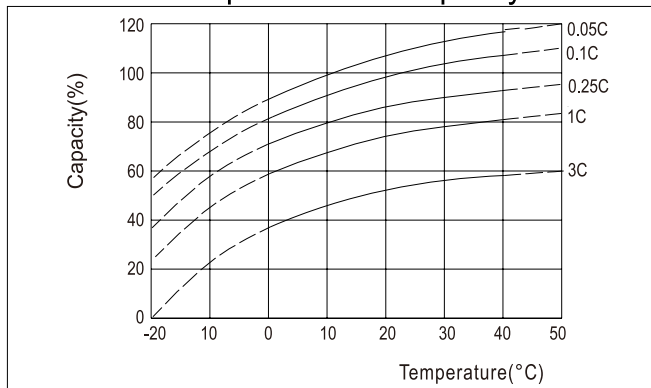

### ● Self-discharge Characteristics

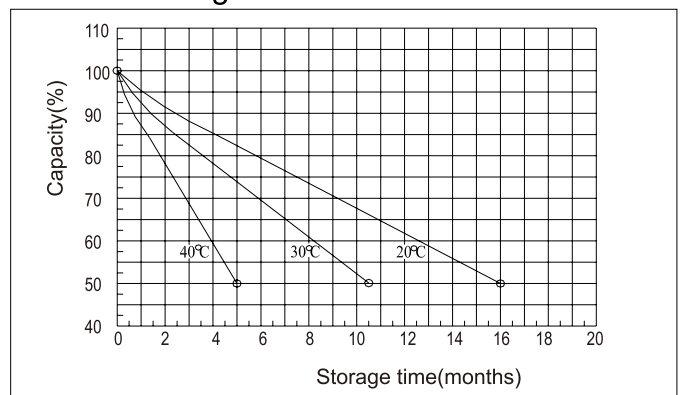

### ● The Relationship for Open Circuit Voltage and Residual Capacity (25°C)

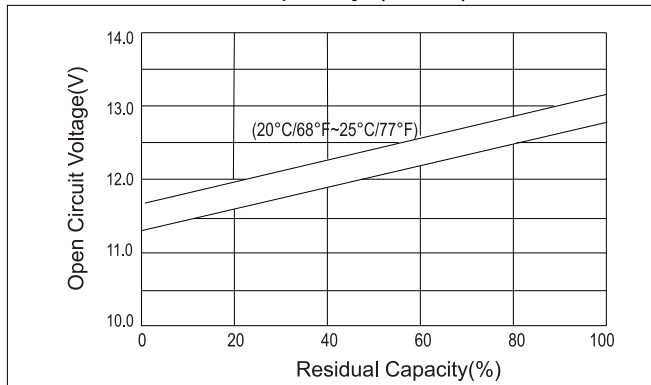

### ● The Relationship for Charging Voltage and Temperature

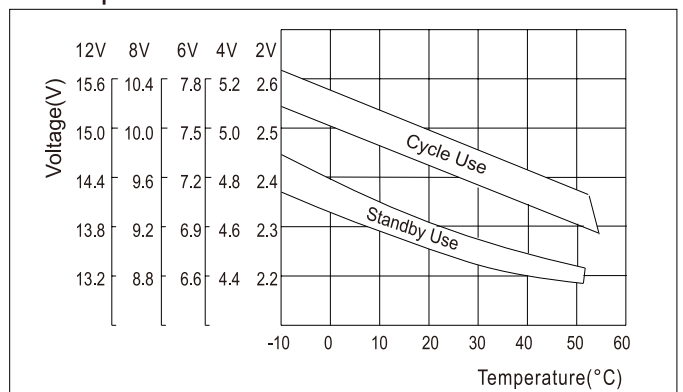

### ● Floating Life on Temperature

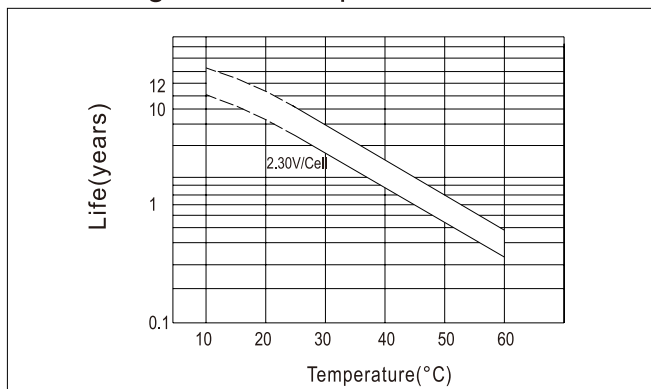

### ● Cycle Life on D.O.D (25°C)

