



● Applications

- Electric tools
- Electric toys
- Emergency lighting
- Electronic instruments
- Medical equipment
- Alarm and security systems
- Solar power systems
- Wind power systems
- Telecommunication equipments
- Uninterruptible power supplies

● Specifications

Nominal Voltage		12V
Rated Capacity (10 hour rate)		55Ah
Dimensions	Total Height	215±2mm(8.45 inches)
	Height	211±2mm(8.30 inches)
	Length	230±2mm(9.10 inches)
	Width	138±2mm(5.43 inches)
Weight Approx		16.9kg(37.18 lbs)±4%

● Outer Dimensions (mm)

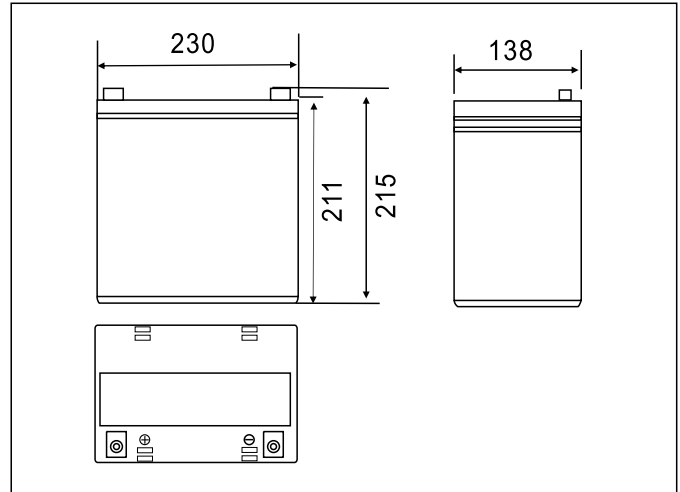

● Characteristics

Capacity 25°C(77°F)	10 hour rate(5.5A) 5 hour rate(9.8A) 1 hour rate(34A)	55 AH 49 AH 34AH
Internal Resistance	Full charged Battery at 25°C(77°F)	6.5mΩ
Capacity affected by Temperature (10hour rate)	40°C(104°F) 25°C(77°F) 0°C(32°F) -15°C(5°F)	102% 100% 85% 65%
Self-Discharge at 25°C(77°F)	Capacity after 3 month storage Capacity after 6 month storage Capacity after 12 month storage	91% 82% 64%
Charge (constant voltage)	Cycle	Initial Charging Current Less than 13.75A Voltage 14.50-14.90V
	Float	Voltage 13.50-13.80V

● Terminal Type (mm)

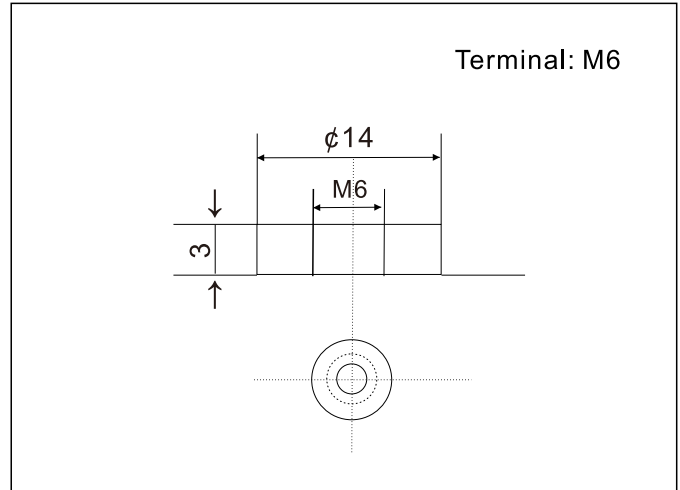

Constant Current(AMP) and Constant Power(Watt) Discharge Table at 25°C(77°F)

Time		10min	15min	30min	1h	2h	3h	4h	5h	8h	10h	20h
9.60V	A	116	90.8	55	34.1	20.1	14	11.5	9.82	6.73	5.60	2.94
	w	1247	996	617	389	233	165	135	116	80	66.9	35.3
9.90V	A	112	88.6	539	33.6	20	13.9	11.4	9.76	6.69	5.59	2.93
	w	1210	973	605	383	231	164	134	115	79.5	66.7	35.2
10.20V	A	107	85.3	52.3	32.7	19.8	13.8	11.4	9.69	6.65	5.57	2.93
	w	1160	937	586	373	229	163	134	115	79.0	66.5	35.1
10.50V	A	103	82.4	51	32.1	19.5	13.8	11.3	9.63	6.60	5.54	2.91
	w	1110	905	572	366	226	162	133	114	78.4	66.1	34.9
10.80V	A	97	78	49.1	31.1	19	13.3	10.9	9.34	6.40	5.50	2.89
	w	1048	857	551	355	220	157	129	110	16.1	65.7	34.7

● Discharge Characteristics(25°C)

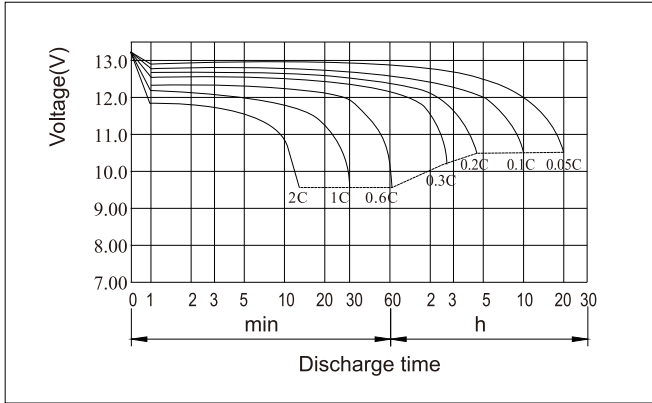

● Charging Characteristics(25°C)

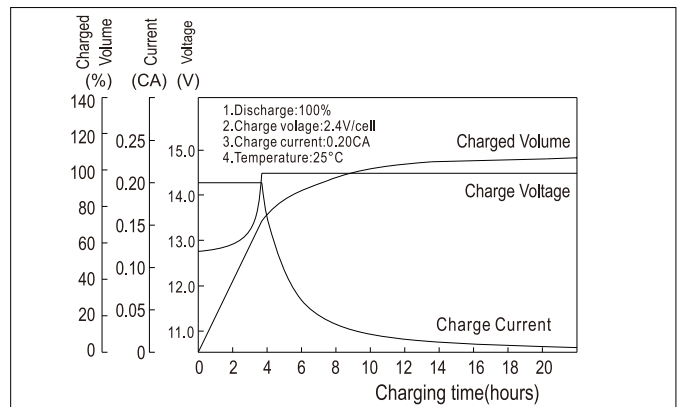

● Effect of Temperature on Capacity

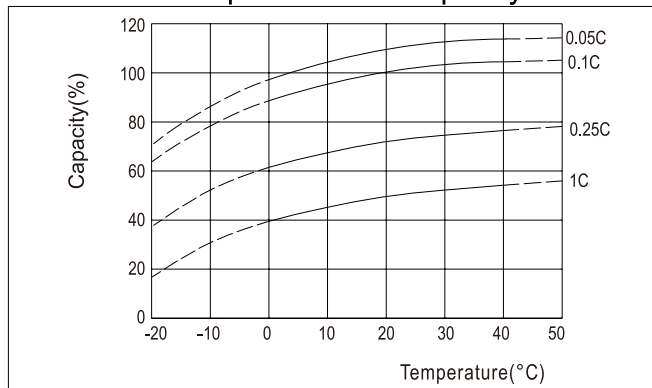

● Self-discharge Characteristics

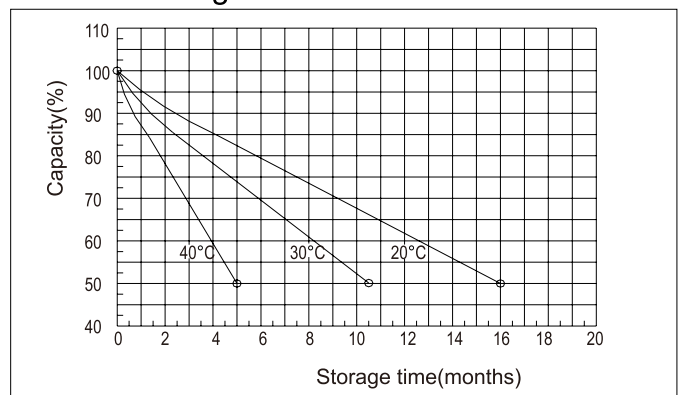

● The Relationship for Open Circuit Voltage and Residual Capacity (25°C)

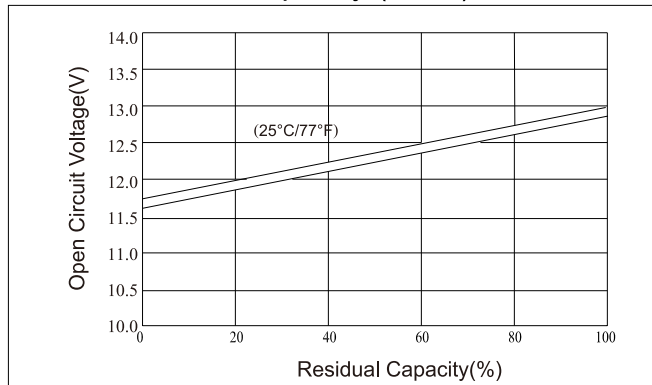

● The Relationship for Charging Voltage and Temperature

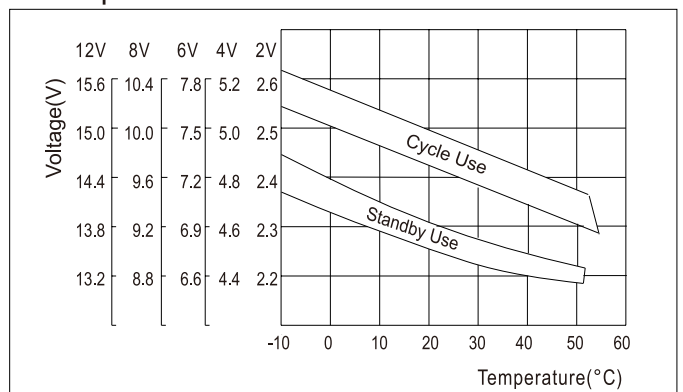

● Floating Life on Temperature

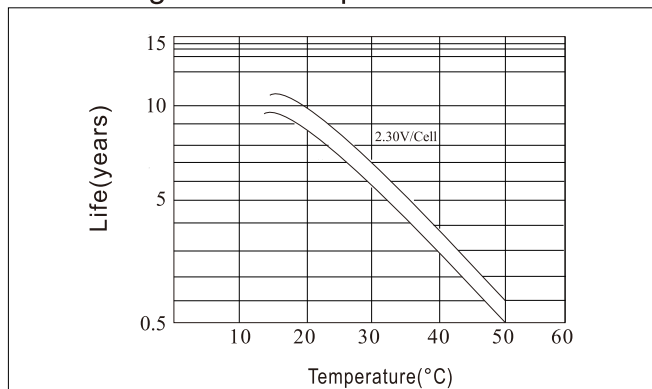

● Cycle Life on D.O.D (25°C)

