



Specifications

Nominal Voltage		12V
Rated Capacity (10 hour rate)		230Ah
Dimensions	Total Height	222±2mm(8.74 inches)
	Height	218±2mm(8.58 inches)
	Length	522±2mm(20.6 inches)
	Width	238±2mm(9.37 inches)
Weight Approx		61.8kg(136.27lbs)±4%

Characteristics

Capacity 25°C(77°F)	10 hour rate(23A)	230 AH
	5 hour rate(41A)	205 AH
	1hour rate(143A)	143AH
Internal Resistance	Full charged Battery at 25°C(77°F)	2.6m Ω
Capacity affected by Temperature (10hour rate)	40°C(104°F)	102%
	25°C(77°F)	100%
	0°C(32°F)	85%
	-15°C(5°F)	65%
Self-Discharge at 25°C(77°F)	Capacity after 3 month storage	91%
	Capacity after 6 month storage	82%
	Capacity after 12 month storage	64%
Charge (constant voltage)	Cycle	Initial Charging Current Less than 57.5A Voltage 14.50-14.90V
	Float	Voltage 13.50-13.80V

Applications

- Electric tools
- Alarm and security systems
- Electric toys
- Solar power systems
- Emergency lighting
- Wind power systems
- Electronic instruments
- Telecommunication equipments
- Medical equipment
- Uninterruptible power supplies

Outer Dimensions (mm)

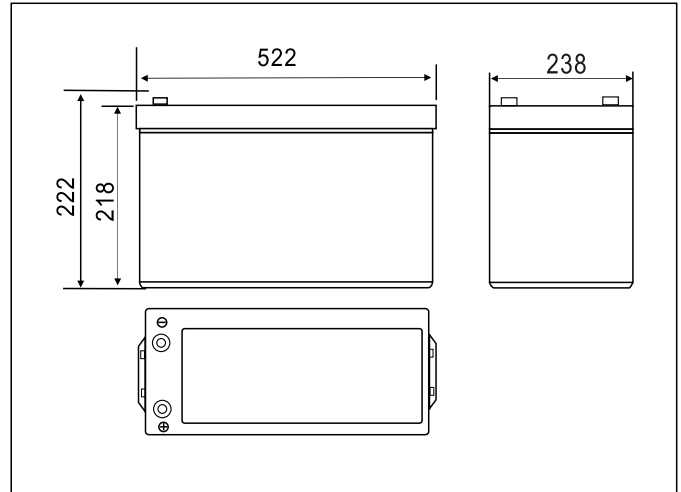

Terminal Type (mm)

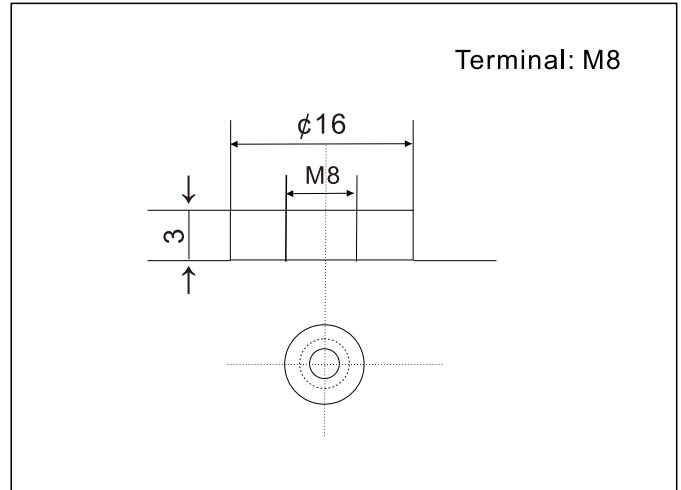

Constant Current(AMP) and Constant Power(Watt) Discharge Table at 25°C(77°F)

Time		15min	30min	1h	2h	3h	4h	5h	6h	8h	10h	20h
9.60V	A	380	230	143	84.0	58.7	48.1	41.1	35.9	28.2	23.4	12.3
	w	4167	2581	1626	973	690	566	485	424	334	280	148
9.90V	A	370	225	140	83.5	58.3	47.8	40.8	35.7	28.0	23.4	12.3
	w	4067	2529	1601	967	686	562	482	422	332	279	147
10.20V	A	357	219	137	82.8	57.9	47.5	40.5	35.4	27.8	23.3	12.2
	w	3917	2452	1561	959	681	558	479	419	330	278	147
10.50V	A	345	213	134	81.6	57.5	47.2	40.3	35.2	27.6	23.2	12.2
	w	3784	2392	1530	944	676	554	476	416	328	277	146
10.80V	A	326	205	130	79.5	55.8	45.7	39.0	34.1	26.8	23.0	12.1
	w	3584	2304	1483	920	656	538	461	403	318	275	145

● Discharge Characteristics(25°C)

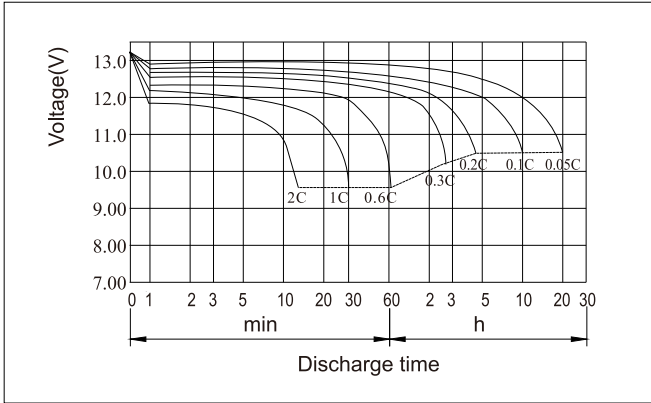

● Charging Characteristics(25°C)

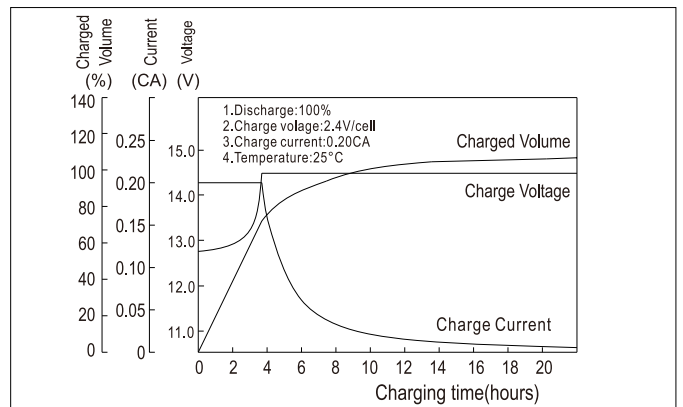

● Effect of Temperature on Capacity

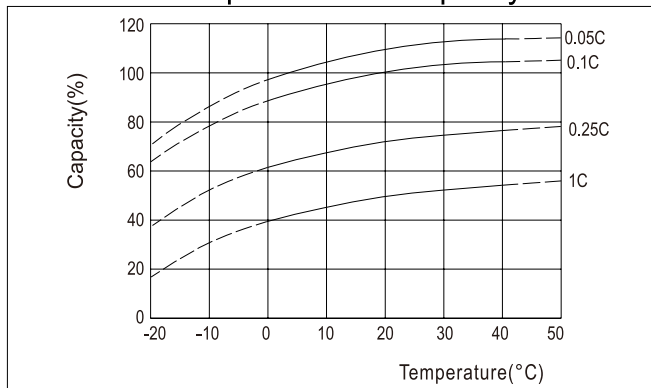

● Self-discharge Characteristics

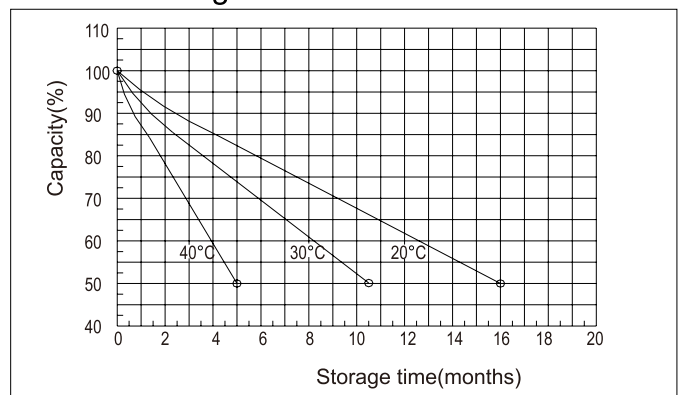

● The Relationship for Open Circuit Voltage and Residual Capacity (25°C)

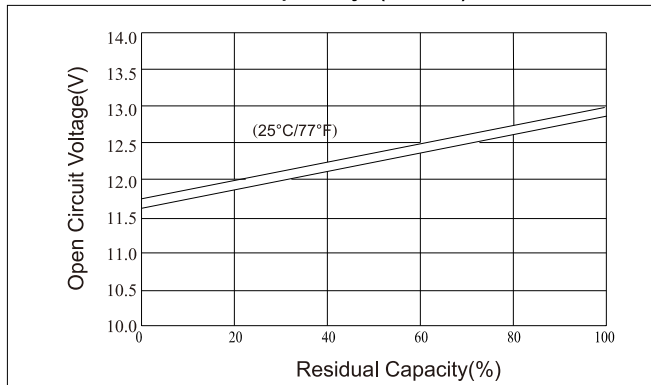

● The Relationship for Charging Voltage and Temperature

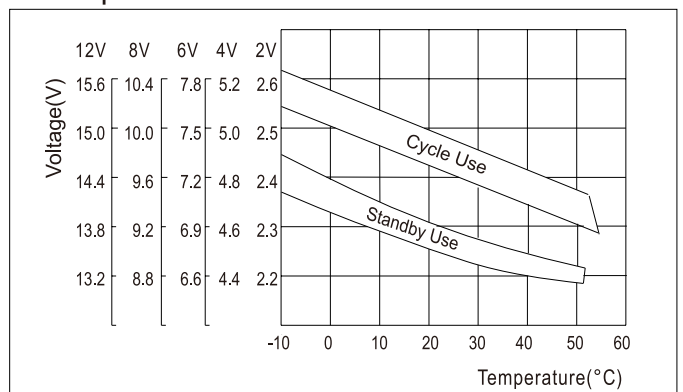

● Floating Life on Temperature

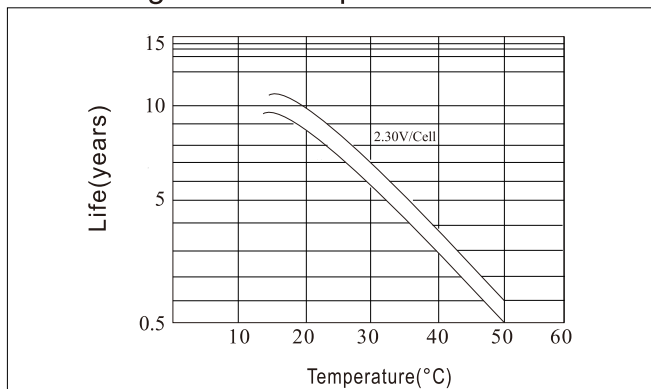

● Cycle Life on D.O.D (25°C)

